



## STAR 6



### GO EVERYWHERE

- > High precision driving & smoothness
- > Comfort & agility
- > Indoor / outdoor rated (versatile)
- > Easy access to the platform
- > Smart transportability & lifting

### WITH THE BEST VALUE FOR MONEY

- > Haulotte Activ'Energy Management takes care of your batteries
- > Easy access to components
- > Smart mast system
- > Minimal maintenance & downtime
- > Direct electric drive with brushless AC motors
- > Haulotte Activ'Screen (onboard diagnostic)

## VERTICAL MASTS

### TECHNICAL DATA

#### STAR 6

Working height	ارتفاع دسترسی	5.8 m
Platform height	ارتفاع تا کف سبد	3.8 m
Horizontal outreach	دسترسی افقی	0.4 m extension (option)
Lift capacity - inside	ظرفیت بالابری	230 kg (2 pers.)
Lift capacity - outside	ظرفیت بالابری	230 kg (1 pers.)
<b>A</b> Length	طول دستگاه	1.4 m
<b>B</b> Width	عرض دستگاه	0.79 m
<b>C</b> Height - stowed	ارتفاع جمع شده	1.8 m
<b>D</b> Wheelbase	فاصله چرخ ها	1.06 m
<b>E</b> Ground clearance	فضای باز دستگاه تا زمین	6 cm
Platform size	ابعاد سبد	0.77 x 1.38 m
Platform size with extension (option)	ابعاد سبد با فضای اضافه شده	0.77 x 1.30 + 0.4 m
Drive speed proportional	سرعت حرکت	0.8 - 4.5 km/h
Turning radius - outside	شعاع گردش	1.7 m
Tilt alarm	هشدار شیب	1.5 ° / 3 °
Gradeability	قابلیت عبور از شیب	25 %
Max driveable platf. height	حداکثر ارتفاع مجاز برای حرکت	3.8 m
Tyres - non marking	نوع لاستیک	318 x 108
Power source	منبع تغذیه	12 V - 105 Ah (C5)
Weight	وزن دستگاه	862 kg

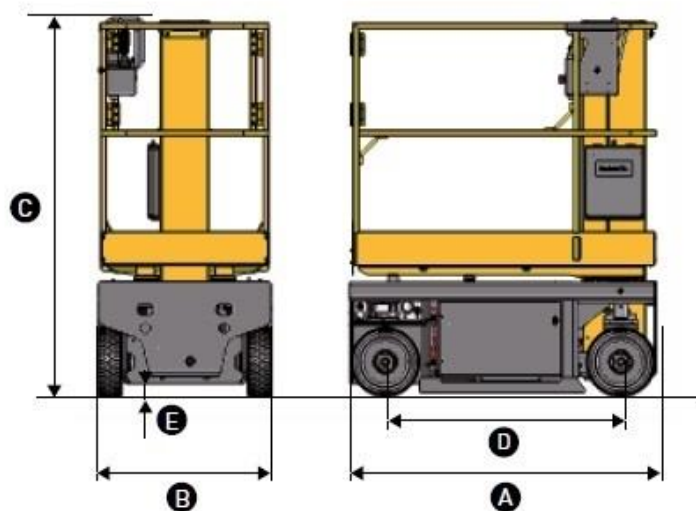

### STANDARD EQUIPMENTS

- > Haulotte Activ'Energy Management: Smart CAN charger
- > 24 V electric drive brushless AC motors
- > 2 x 12 V - 105 Ah batteries
- > Battery charge indicator
- > Haulotte Activ'Screen
- > Fork lifting eyes
- > Hoisting and lifting eyes
- > Swing door entry gate
- > Mobile potholes
- > 2 front steering wheels
- > 2 rear driving wheels
- > Non marking tyres
- > Brake release
- > Hourmeter
- > Horn
- > Travel alarm
- > Emergency stop
- > Emergency hand pump
- > 2 control stations at cage and ground level
- > Mobile upper control box
- > 2 towing hooks
- > Protection baseboard
- > Overload sensor

### OPTIONS AND ACCESSORIES

- > Haulotte Activ'Energy Management: automatic or manual battery waterfilling systems
- > Upper control box protection cover
- > Tool tray
- > Platform extension deck + 0.4 m (height stowed: 1.8 m)
- > Power line in platform
- > Ground-fault circuit interrupter 30 mA
- > Telematics ready
- > Biodegradable oil
- > Hydraulic oil for cold countries
- > Flashing light
- > Fluorescent tube caddy

