

STAR 6 CRAWLER



GO EVERYWHERE

- > High-precision driving & smoothness
- > Intermediate supporting wheels in crawler track system
- > Ability to go through uneven grounds and water puddles
- > Dedicated forklift pockets

GREAT AGILITY IN CONFINED WORKING AREA

- > Compact machine: only 0.76 m width
- > Low turning radius
- > + 0.4 m platform extension
- > Platform with dedicated anti-slip step
- > Ergonomic & intuitive platform control box with battery level indicator

OPTIMAL TOTAL COST OF OWNERSHIP

- > 3-stage-cylinder mast: no chain & no cable
- > Direct electric drive brushless AC motors
- > Easy access to components (hoods and dedicated hand pump)
- > Onboard diagnostic: Haulotte Activ'Screen



STAR 6 CRAWLER

VERTICAL MASTS

TECHNICAL DATA

STAR 6 CRAWLER

Working height	ارتفاع دسترسی	5.8 m
Platform height	ارتفاع تا کف سبد	3.8 m
Horizontal outreach	دسترسی افقی	0.4 m extension
Lift capacity - inside	ابعاد سبد قسمت باز شده	200 kg (2 pers.)
Lift capacity - outside	ظرفیت بالابری	200 kg (1 pers.)
Platform size	ابعاد سبد	0.74 m x 1.0 m
Platform size with extension	ابعاد سبد قسمت باز شده	0.74 m x 1.44 m
A Length	طول دستگاه	1.44 m
B Width	عرض دستگاه	0.76 m
C Height - stowed	ارتفاع جمع شده	1.72 m
D Ground clearance	فضای باز دستگاه تا زمین	6 cm
Drive speed proportional	سرعت حرکت	0.8 - 2.2 km/h
Turning radius - outside	شعاع گردش	1.25 m
Tilt alarm	هشدار شیب	1.5° / 3°
Gradeability	قابلیت عبور از شیب	25 %
Max driveable platf. height	حداکثر ارتفاع مجاز برای حرکت	0.7 m
Rubber tracks - non marking	نوع و ابعاد لاستیک	180 x 72 x 43
Power source	منبع تغذیه	2 x 12 V - 115 Ah (C5)
Hydraulic system capacity	ظرفیت روغن هیدرولیک	5 l
Weight	وزن دستگاه	1 175 kg

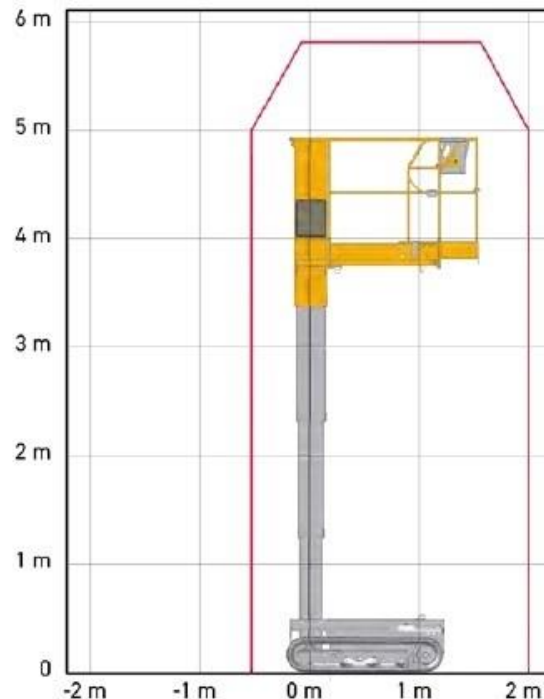
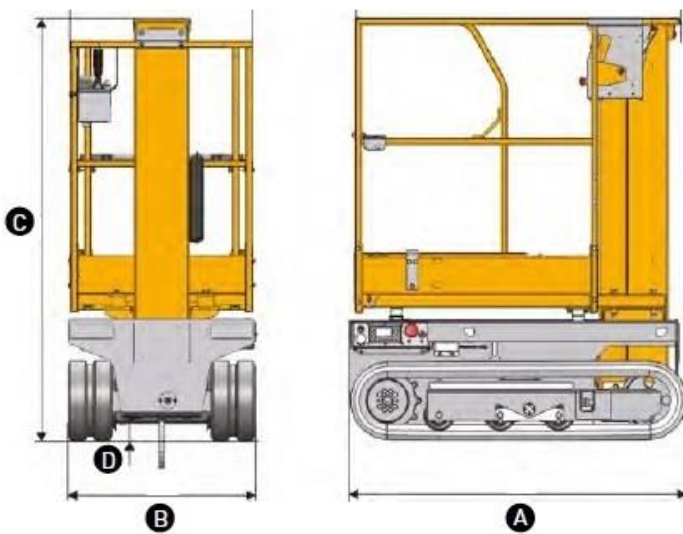

STANDARD EQUIPMENT

- > Motion movement only in stowed position
- > 24 V electric drive brushless AC motors
- > 20 A battery charger
- > 2x12 V - 115 Ah maintenance-free batteries
- > Battery level indicator
- > Haulotte Activ'Screen
- > Fork lifting pockets
- > Hoisting and lifting eyes
- > Door entry gate with lock
- > 2 drive speed
- > 2 steering and driving non marking rubber tracks
- > Hourmeter
- > Horn
- > Travel alarm
- > Emergency stop at cage and ground level
- > Lowering system
- > Handing pump for platform elevation
- > Control stations at cage and ground level
- > Mobile upper control box
- > 2 towing hooks
- > Platform extension deck + 0.4 m

OPTIONS AND ACCESSORIES

- > Lockable battery circuit breaker
- > Upper control box protection plastic cover
- > Joystick protection
- > Deadman pedal
- > Flashing light
- > Hydraulic oil for cold countries
- > Biodegradable oil