

## ROUGH TERRAIN ARTICULATING BOOMS

# HA20 RTJ PRO



### PERFORMANCE & EASE OF USE

- > Best lifting speed of 48 sec.
- > Industry leading working envelope with an outreach of 12.2 m
- > Fully proportional and simultaneous movements
- > Ease of transport

### EXCELLENT ROBUSTNESS

- > Rugged hoods with ergonomic handle
- > Long lasting structural design

### MINIMIZED TOTAL COST OF OWNERSHIP

- > Haulotte Activ'Screen (on board diagnostic)
- > Haulotte Stop Emission System: automatically turns the engine off & on
- > Exclusive modular basket with upper control box cover and tool tray
- > Easy access to all components

### BEST COMFORT AND SAFETY FEELING

- > Haulotte Activ'Shield Bar 2.0

# HA20 RTJ PRO

## ROUGH TERRAIN ARTICULATING BOOMS

### TECHNICAL DATA

#### HA20 RTJ PRO

Working height	ارتفاع دسترسی	20.6 m
Platform height	ارتفاع تا کف سبد	18.6 m
Horizontal outreach	دسترسی افقی	12.2 m
Up and over clearance	فضای باز مورد نیاز	8.4 m
Lift capacity	ظرفیت بالابری	230 kg (2 pers.)
<b>F</b> x <b>G</b> Platform size	ابعاد سبد	1.83 x 0.80 m
<b>A</b> Length - stowed	طول-در حالت جمع شده	8.8 m
<b>B</b> Width	عرض دستگاه	2.42 m
Height - stowed	ارتفاع-در حالت جمع شده	2.51 m
<b>H</b> Storage / transport length	طول-در حالت حمل و نقل	6.5 m
<b>C</b> Storage / transport height	ارتفاع-در حالت حمل و نقل	2.93 m
Vertical jib rotation	چرخش عمودی جیب	140° (+ 60° / - 80°)
Platform rotation	چرخش سبد	180° (+ 90° / - 90°)
Turntable rotation	چرخش صفحه گردان	360° continuous
Tailswing	شعاع چرخش دم	14.2 cm
<b>D</b> Wheelbase	فاصله چرخ ها	2.45 m
<b>E</b> Ground clearance	فضای باز دستگاه تا زمین	42 cm
Tilt	زاویه شیب	5°
Drive speed	سرعت حرکت	0,5 - 5 km/h
Gradeability	قابلیت عبور از شیب	45 %
Tyres - solid rough terrain	لاستیک	1 025 x 365 mm
Turning radius - outside	شعاع چرخش به خارج	3,75 m
Power source	منبع تغذیه	Stage 5: Kubota 37 kW, Kohler 36,5 kW Stage 3A: Kubota, 36.5kW (NRC)
Weight	وزن دستگاه	9 600 kg

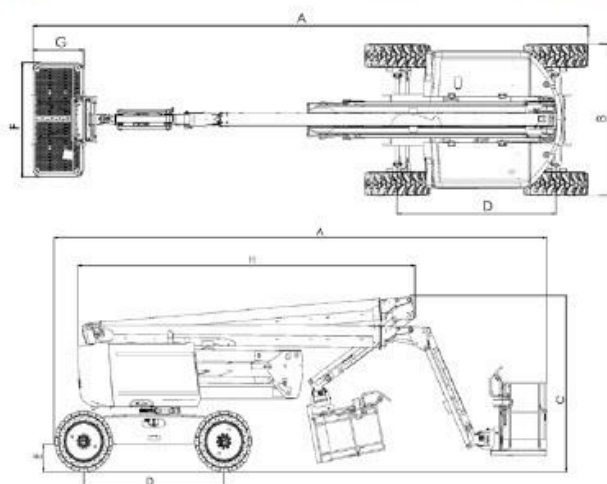

### STANDARD EQUIPMENT

- > Haulotte Activ'Screen
- > Haulotte Activ'Shield Bar 2.0
- > Haulotte Stop Emission System
- > Universal telematics plug
- > Rotating beacon
- > Front oscillating axle increases stability on uneven ground
- > 4 wheel drive, 4 wheel steer
- > Permanent limited slip differential
- > 4 simultaneous movements for maximum productivity
- > Modular standard basket 1.83 m x 0.80 m, drop bar entry gate
- > Upper control box protection cover and tool tray in plastic ultra-solid
- > AC power to platform 110 / 230 V
- > Travel alarm
- > Electric pump system and emergency descent
- > 12 V battery
- > Sound and light alarm for tilt and load
- > Hour meter
- > Low fuel level indicator (upper & lower control boxes)
- > Swing out engine tray for ease of maintenance

### OPTIONS AND ACCESSORIES

- > Glazier pack
- > Non-marking tires
- > Biodegradable hydraulic oil
- > Hot weather kit: hydraulic oil cooler + hydraulic oil
- > Cold weather kit: - 10°C / - 25°C
- > Flashing light
- > Power to platform 110 / 230 V (with or without circuit-breaker 30 mA)
- > 55 W working light
- > Air-line to platform 6.5 mm inner diameter
- > Hydraulic generator Dynaset 3.5 Kw
- > Lateral swing door entry gate
- > Large modular basket 2.44 m x 0.91 m

