



Excellent manoeuvrability in the tightest spaces

- Compact size with 1.35 m width
- Stowed height can pass through a standard doorway
- 136° (+64°/-72°) fly jib range of motion
- Tight turning radius (2.4 m)

Optimal productivity and comfort

- 6.5 m outreach
- Long working cycles
- Full proportional controls

Robust, reliable and easy to maintain



© Alina Périer

www.haulotte.com

Haulotte 
GROUP

More than lifting



HA12 IP

ELECTRIC ARTICULATING BOOMS

TECHNICAL DATA

HA12 IP

Working height	ارتفاع دسترسی	12 m
Platform height	ارتفاع تا کف سبد	10 m
Horizontal outreach	دسترسی افقی	6.5 m
Up and over clearance	فضای باز مورد نیاز	5.3 m
Lift capacity	ظرفیت بالابری	230 kg
Vertical jib rotation	چرخش عمودی جیب	136° (+64/-72)
A Length	طول دستگاه	5.4 m
B Width	عرض دستگاه	1.35 m
C Height - stowed	ارتفاع-در حالت جمع شده	2.06 m
Height - transport	ارتفاع-در حالت حمل و نقل	2.6 m
D Wheelbase	فاصله چرخ ها	1.8 m
E Ground clearance	فضای باز دستگاه تا زمین	16 cm
F x G Platform size	ابعاد سبد	1.2 x 0.8
Tailswing	شعاع چرخش دم	0 cm
Proportional drive speed	سرعت حرکت	0.7 - 4.5 km/h
Turning radius - outside	شعاع چرخش به خارج	2.4 m
Turntable rotation	چرخش صفحه گردان	355 °
Platform rotation	چرخش سبد	170° (+80/-90)
Energy	انرژی	48 V - 345 Ah (C5)
Gradeability	قابلیت عبور از شیب	25 %
Tyres - non marking	لاستیک	6x12"
Hydraulic system capacity	ظرفیت هیدرولیک	30 l
Weight	وزن دستگاه	5 945 kg

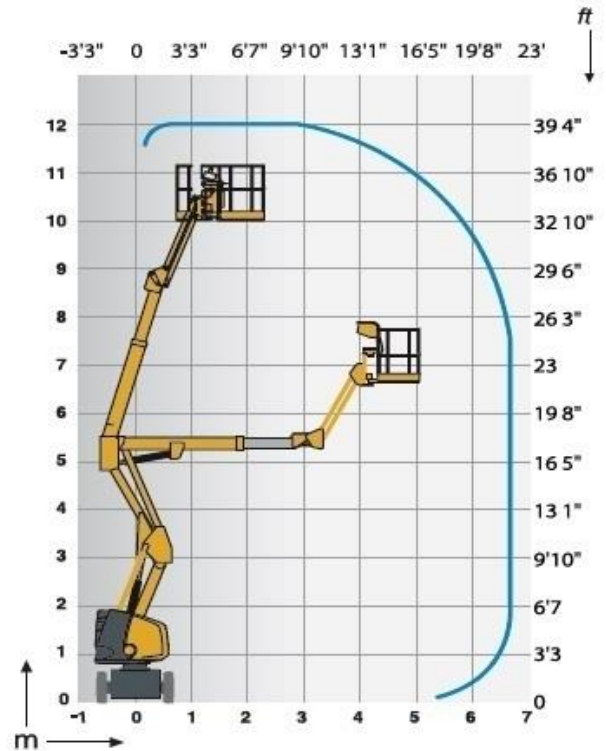

STANDARD EQUIPMENT

- Semi-traction battery
- Battery charge indicator
- 48 V – 50 A battery charger
- Sensitive control box
- 3° Tilt alarm
- Non marking tyres
- Outside / inside use: wind rated to 45 km/h
- Brake release
- Hourmeter
- Slewing block pin
- Towing hooks and lifting eyes
- Emergency hand pump
- 2 wheel drive and steer
- Load limiter in cage
- Horn

OPTIONS AND ACCESSORIES

- Flashing light
- Power to platform
- Travel alarm
- Centralised battery filling
- 360 Ah traction batteries
- Waterproof batteries
- Air line to cage
- Electric remote brake release
- Biodegradable oil
- Large basket option 1.4m x 0.8m (lift capacity 200 kg)

