

## SIGMA 16 SIGMA 16 PRO



### BOOST YOUR PRODUCTIVITY

- > Best working envelope in the market with the longest outreach and highest up & over clearance
- > Simultaneous movements
- > Versatility indoor & outdoor on firm ground
- > Load capacity of 230 kg & two operators

### MOVE WITH AGILITY

- > Jib with horizontal rotation provides access to the most inaccessible places (PRO model)
- > Zero tailswing and tight turning radius
- > Proportional, precise & smooth movements

### RELIABLE SERVICEABILITY

- > Haulotte Activ'Energy Management takes care of your battery
- > Haulotte Activ'Screen: on-board configuration & diagnostic interface

### WORK SAFELY

- > Haulotte Activ'Shield Bar \*
- > Haulotte Activ'Lighting System \*

\* Optional on SIGMA 16 model



# SIGMA 16 SIGMA 16 PRO

## ELECTRIC ARTICULATING BOOMS

### TECHNICAL DATA

		SIGMA 16	SIGMA 16 PRO
Working height	ارتفاع دسترسی	16.1 m	15.7 m
Platform height	ارتفاع نا کف سبد	14.1 m	13.7 m
Horizontal outreach	دسترسی افقی	8.35 m	8.05 m
Up and over clearance	فضای باز مورد نیاز	7.4 m	
Lift capacity	ظرفیت بالابری	230 kg (2 pers.)	
<b>A</b> Length	طول دستگاه	6.6 m	6.65 m
<b>B</b> Width	عرض دستگاه	1.75 m	
<b>C</b> Wheelbase	فاصله چرخ ها	2 m	
<b>D</b> Ground clearance	فضای باز مرکز دستگاه تا زمین	17 cm	
<b>E</b> x <b>F</b> Platform size	ابعاد سبد	1.2 x 0.8 m	
Height - stowed	ارتفاع- در حالت جمع شده	2 m	
<b>A</b> Storage / transport length	طول- در حالت حمل و نقل	6.6 m	6.65 m
Tailswing	شعاع چرخش دم	0 cm	
Vertical jib rotation	چرخش عمودی جیب	-65° / +65°	
Horizontal jib rotation	چرخش افقی جیب	N/A	-55° / +55°
Platform rotation	چرخش سبد	-85° / +85°	
Turntable rotation	چرخش صفحه گردان	355 °	
Tilt	زاویه شیب	4°/4°	
Proportional drive speed	سرعت حرکت	5 km/h	
Maximum wind speed rating	حداکثر سرعت مجاز باد برای کار	45 km/h	
Gradeability	قابلیت عبور از شیب	25 %	
Turning radius - outside	شعاع چرخش به خارج	3.9 m	
Tyres - non marking	لاستیک	676 x 231 mm	
Weight	وزن دستگاه	6 900 kg	6 950 kg
Batteries	باتری	8 x 6 V - 435 Ah (C20)	

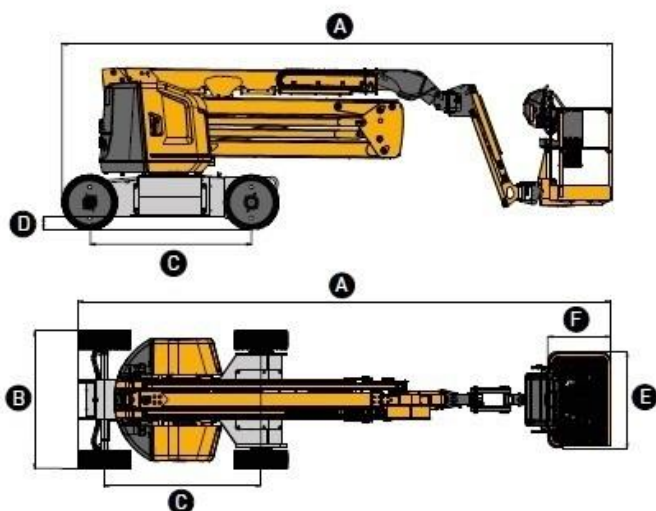

### STANDARD EQUIPMENTS

- > Jib with horizontal rotation (PRO model)
- > 2 wheel drive / 2 wheel steer
- > AC motors
- > 48V battery pack
- > Haulotte Activ'Energy Management: smart battery management system
- > Haulotte Activ'Shield Bar 2.0\*
- > Haulotte Activ'Lighting System for safe loading in low visibility conditions\*
- > Haulotte Activ'Screen: embedded diagnostic system, with color screen
- > Upper control box cover\*
- > Tool tray\*
- > 1.2 m wide basket
- > Drop bar entry
- > Large solid, non-marking industrial tires
- > AC power to basket
- > Lockable battery circuit breaker
- > Motion alarm

### OPTIONS AND ACCESSORIES

- > Side swing door + front drop bar
- > 1.5 m basket
- > Cones holder
- > Fluorescent tube holder
- > Basket plug (110 / 230 V)
- > Cold countries hydraulic oil
- > Haulotte Activ'Energy Management: manual or automatic battery water-filling system
- > USB plug
- > Telematics solutions

\* Optional on SIGMA 16 model

